

PRESSURE FILTER

Series LF 63 363 PSI

Sheet No.
1109 G

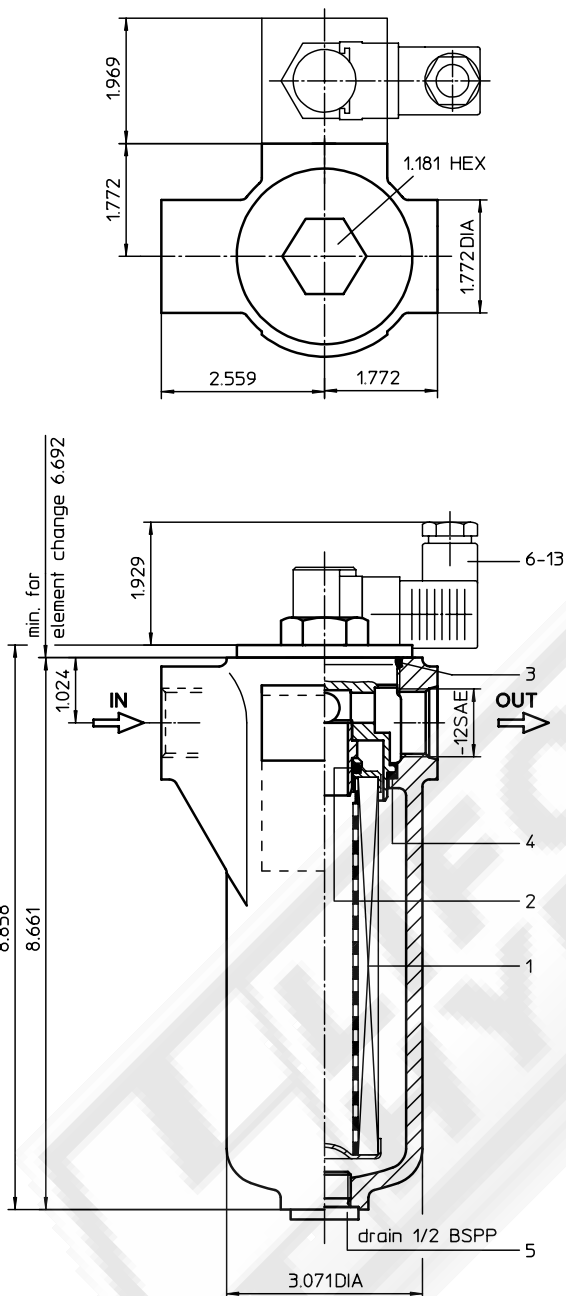

1. Type index:

1.1. Complete filter: (ordering example)

LF. 63. 10VG. 30. E. P. - UG. 4. - - AE

1	2	3	4	5	6	7	8	9	10	11	12
---	---	---	---	---	---	---	---	---	----	----	----

- 1 **series:**
LF = in-line filter
- 2 **nominal size:** 63
- 3 **filter-material and filter-fineness:**
80 G = 80 μm , 40 G = 40 μm , 25 G = 25 μm
stainless steel wire mesh
25 VG = 20 $\mu\text{m}_{(c)}$, 16 VG = 15 $\mu\text{m}_{(c)}$, 10 VG = 10 $\mu\text{m}_{(c)}$,
6 VG = 7 $\mu\text{m}_{(c)}$, 3 VG = 5 $\mu\text{m}_{(c)}$ Interpor fleece (glass fiber)
- 4 **resistance of pressure difference for filter element:**
30 = Δp 435 PSI
- 5 **filter element design:**
E = single-end open
- 6 **sealing material:**
P = Nitrile (NBR)
V = Viton (FPM)
- 7 **filter element specification:** (see catalog)
- = standard
VA = stainless steel
IS06 = see sheet-no. 31601
IS07 = see sheet-no. 31602
- 8 **connection:**
UG = thread connection
- 9 **connection size:**
4 = -12 SAE
- 10 **filter housing specification:** (see catalog)
- = standard
IS06 = see sheet-no. 31605
- 11 **internal valve**
- = without
S1 = with by-pass valve Δp 51 PSI
- 12 **clogging indicator or clogging sensor:**
- = without
AOR = visual, see sheet-no. 1606
AOC = visual, see sheet-no. 1606
AE = visual-electrical, see sheet-no. 1615
VS1 = electronical, see sheet-no. 1617
VS2 = electronical, see sheet-no. 1618

1.2. Filter element: (ordering example)

01NL. 63. 10VG. 30. E. P. -

1	2	3	4	5	6	7
---	---	---	---	---	---	---

- 1 **series:**
01NL. = standard filter element according to DIN 24550, T3
- 2 **nominal size:** 63
- 3 - 7 | see type index-complete filter

weight: 4.40 lbs.

Changes of measures and design are subject to alteration!

EDV 08/03

2. Spare parts:

item	qty.	designation	dimension	article-no.	
1	1	filter element	01NL. 63		
2	1	O-ring	22 x 3,5	304341 (NBR)	304392 (FPM)
3	1	O-ring	56 x 3	305072 (NBR)	305322 (FPM)
4	1	O-ring	48 x 3	304357 (NBR)	304404 (FPM)
5	1	screw plug	½ BSPP	304678	
6	1	clogging indicator, visual	AOR or AOC	see sheet-no. 1606	
7	1	clogging indicator, visual-electrical	AE	see sheet-no. 1615	
8	1	clogging sensor, electronical	VS1	see sheet-no. 1617	
9	1	clogging sensor, electronical	VS2	see sheet-no. 1618	
10	1	O-ring	15 x 1,5	315357 (NBR)	315427 (FPM)
11	1	O-ring	22 x 2	304708 (NBR)	304721 (FPM)
12	1	O-ring	14 x 2	304342 (NBR)	304722 (FPM)
13	2	screw plug	1/8 BSPP	305496	

item 13 execution only without clogging indicator or clogging sensor

3. Description:

In-line filters of the type LF 63 are suitable for a working pressure up to 363 PSI.

Pressure peaks are absorbed with a sufficient margin of safety.

The filter is mounted in such a way that inlet and outlet are on the same level. It can be used as suction filter, pressure filter and return-line filter. The filter element consists of star-shaped, pleated filter material which is supported on the inside by a perforated core tube and is bonded to the end caps with a high-quality adhesive. The flow direction is from outside to inside.

The particles are held back on the outside. For cleaning (see special leaflet 21070-4) the mesh element respectively to change the glass fiber element remove the cover and take out the element.

Filter finer than 40 µm should use throw-away elements made of paper or Interpor fleece (glass fiber). Filter elements as fine as 5 µm_(c) are available; finer filter elements on request.

INTERNORMEN-Filter elements are known as elements with a high intrinsic stability and an excellent filtration capability, a high dirt-retaining capacity and a long service life.

INTERNORMEN-Filter are suitable for all petroleum based fluids, HW-emulsions, most synthetic hydraulic fluids and lubrication oils. Approvals according to TÜV, and the major „Shipyards Classification Societies“ D.N.V.; B.V.; G.L.; L.R.S.; R.I.N.A.; A.B.S. and others are possible.

The internal valve is integrated in the filter cover.

After reaching the opening pressure the by-pass valve causes that an unfiltered partial flow passes the filter.

4. Technical data:

temperature range:	+14°F to +176°F (for a short time +212°F)
operating medium:	mineral oil, other media on request
max. operating pressure:	363 PSI
test pressure:	479 PSI
connection system:	thread connection
housing material:	aluminium-cast
sealing material:	Nitrile (NBR) or Viton (FPM), other materials on request
installation position:	vertical
mini-measuring connection:	¼ BSPP
evacuation-or bleeder-connection:	½ BSPP
volume tank:	.18 Gal.

Classified under the Pressure Vessel Directive 97/23/EC for mineral oil (fluid group 2), Article 3, Para. 3.

Classified under ATEX Directive 94/9/EC according to specific application (see questionnaire sheet-no. 34279-4).

5. Symbols:

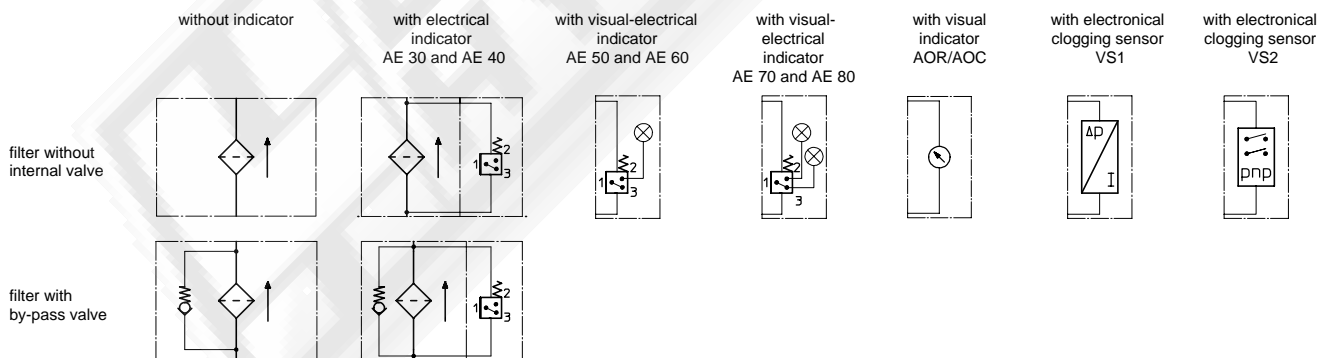

6. Pressure drop flow curves: Precise flow rates see 'INF-Expert-System Filter', respectively Δp -curves; depending on filter fineness and viscosity.

7. Test methods:

Filter elements are tested according to the following ISO standards:

- ISO 2941 Verification of collapse/burst resistance
- ISO 2942 Verification of fabrication integrity
- ISO 2943 Verification of material compatibility with fluids
- ISO 3723 Method for end load test
- ISO 3724 Verification of flow fatigue characteristics
- ISO 3968 Evaluation of pressure drop versus flow characteristics
- ISO 16889 Multi-pass method for evaluating filtration performance